



Static Curtain Fire Damper - MODEL 150A

Features – U. L. Rated for 1-1/2 hour fire damper, for use in a 2 hour fire partition. • Meets NFPA 90A & UL555

STANDARD CONSTRUCTION

FRAME

4-7/8" deep, 22 gauge galvanized steel

BLADES

3-3/8" wide, 22 gauge galvanized steel

UNDERSIZED

1/4" under ordered size unless specified otherwise

FUSIBLE LINK

165° Standard (others available)

SPRING

Stainless Steel – 301 Negator type

Vertical – Optional

Horizontal – Standard

MINIMUM SIZE

4"w x 4"h (Vertical & Horizontal)

MAXIMUM SINGLE SECTION SIZE

Vertical – 60"w x 60"h

Horizontal – 48"w x 48"h

MAXIMUM MULTIPLE SECTION SIZE

Vertical – 120"w x 80"h (40" x 40" Single Section)

Horizontal – 97"w x 42"h (36" x 42" Single Section)

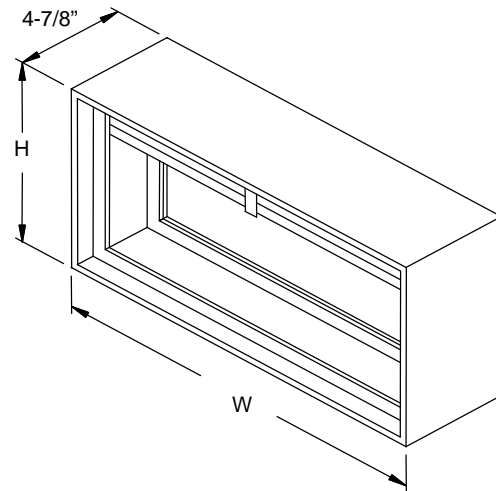

OPTIONAL CONSTRUCTION

SPRING - Available in vertical mount

FRAME – Available in Stainless Steel

BLADE – Available in Stainless Steel

FUSIBLE LINK – Electrically triggered link (ETL)

SLEEVE & DUCT CONNECTION – 10 ga. to 20 ga. galvanized steel to 30" in length. Transitions available in; round, oval, rectangular, or custom. Factory can install access door, retaining angles, flange connections or security bars.

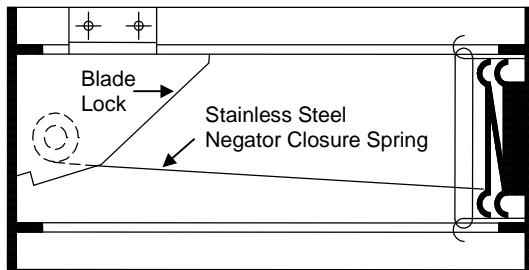

Horizontal Section

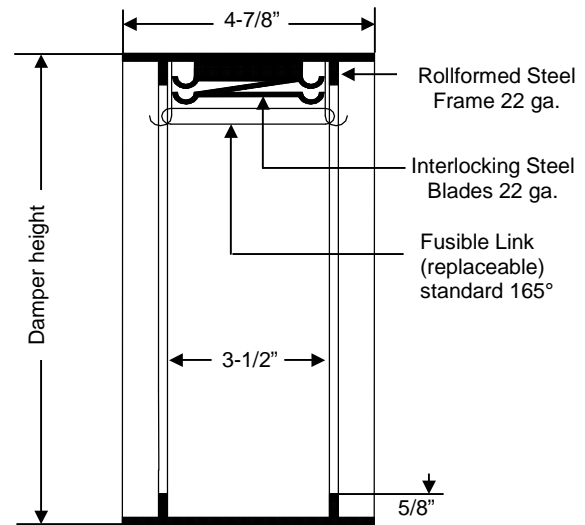

Vertical Section

Contractor
Project
Engineer

IMPERIAL DAMPER & LOUVER LLC
4228-38 Park Avenue
Bronx, New York 10457
Phone: 718-731-3800 Fax: 718-731-4920
Email: Sales@ImperialDamper.com
Web: www.ImperialDamper.com