



Control Damper Model 610 & 611

Design Features – Nested closure “V” blade design that provides a greater sealing surface than competitive designs.

STANDARD CONSTRUCTION

FRAME

4-5/16” deep, 16 gauge galvanized steel

BLADES

6” wide, 16 gauge galvanized steel
(Bottom blade width may vary depending on damper height)

BLADE AXLES & BEARINGS

AXLE – 7/16” Plated hex
BEARING – Bronze oil impregnated

LINKAGE

610 - Plated steel concealed inside of jamb
611 – Plated steel mounted mid span of blade
Drive blade has a 1” to 6” extendable shaft to mount operator

MAXIMUM SIZE

Unlimited, with mullions, structural bracing supplied by others
(Multi-section sizes usually require jackshaftering)

MAXIMUM SINGLE SECTION

48”H x 72”H

MINIMUM SIZE

4”W x 4”H

SEALS

Optional

UNDERSIZED

1/4” under ordered size unless specified Exact or Actual

FINISH

Mill

OPERATOR

None

OPTIONAL CONSTRUCTION

FRAME – Available in heavier galvanized construction up to 10 gauge

BLADES – Available in heavier galvanized construction up to 10 gauge

SPECIFIED MATERIAL – Available in stainless, Aluminum or as requested

LINKAGE – Mounted on face of blades in either opposed or parallel

BLADE & JAMB SEALS – Silicone blade edge and/or stainless steel jamb seals

SLEEVE AND DUCTWORK CONNECTION – 10 ga. to 20 ga. galvanized steel to 30” in length. – Transitions available in: round, oval, rectangular or custom. Factory can install access door, retaining angles, or flange connections.

FINISH – Air-dry primer, polyurethane, epoxy, or enamel, Baked epoxy or enamel, or Powder coat.

OPERATOR – Manual, electric or pneumatic, internally or externally mounted, please consult operator listing

SPECIAL PURPOSE CONSTRUCTION

Fully welded corner assembly

Security bars (mounted in sleeve)

Filter racks

Face and bypass dual mixing damper configuration

* Dampers 11” high and under will be single blade, and extend from the frame proportionately.

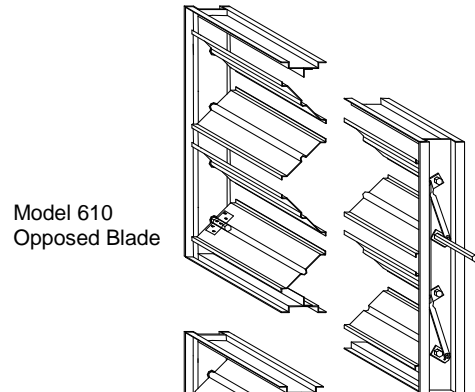

Model 610
Opposed Blade

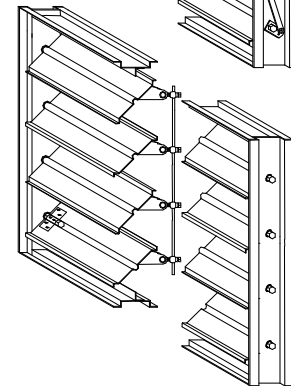

Model 611
Parallel Blade

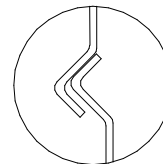

Blades closed
without seal

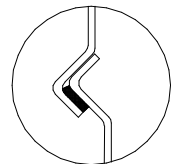

Blades closed
with seal
(optional)

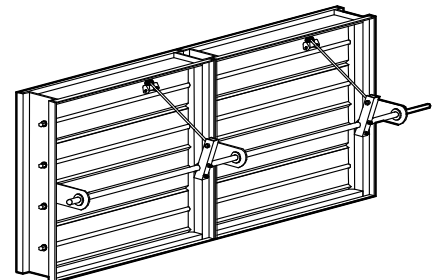

Typical jackshaftered multiple section assembly

| |
|-------------------|
| Contractor |
| Project |
| Engineer |

IMPERIAL DAMPER & LOUVER LLC
4228-38 Park Avenue
Bronx, New York 10457
Phone: 718-731-3800 Fax: 718-731-4920
Email: Sales@ImperialDamper.com
Web: www.ImperialDamper.com



AIR PERFORMANCE

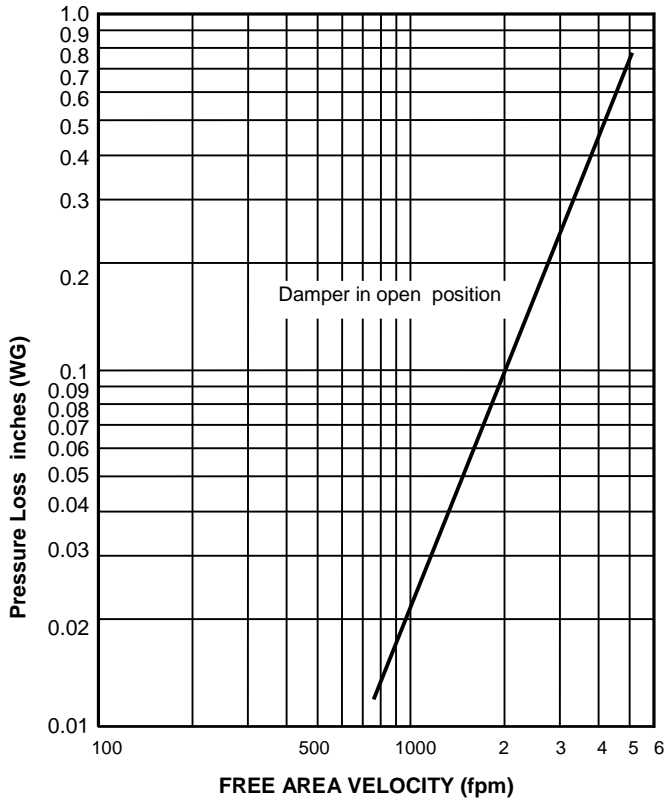

AIR LEAKAGE

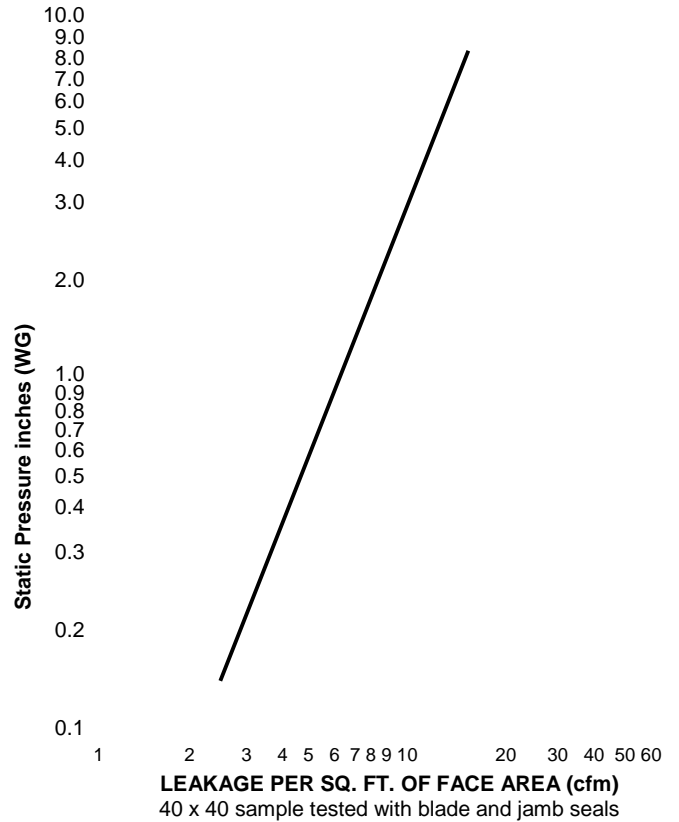

CALCULATING PRESSURE LOSS:

Based upon a given flow rate (in CFM), the flowing pressure loss may be determined from the "air performance graph, knowing the sq. ft. of free area of the damper. Alternately, the free area may be determined based upon a volumetric flow rate and a maximum pressure loss. Utilizing the "air performance" graph.

_____ in. W.C. Max. Pressure Loss Intake or Exhaust
 _____ FPM (Free Area Velocity From "Air Performance" Graph)
 _____ CFM / _____ FPM Free Area Velocity = _____ Sq. Ft. Free Area

FREE AREA CALCULATIONS IN SQ. FT.

| HEIGHT | WIDTH | | | | | | | | | | |
|--------|--------|------|------|------|-------|-------|-------|-------|-------|-------|----|
| | Inches | 12 | 16 | 20 | 24 | 28 | 32 | 36 | 40 | 44 | 48 |
| 12 | 0.58 | 0.81 | 1.03 | 1.26 | 1.49 | 1.72 | 1.95 | 2.17 | 2.40 | 2.63 | |
| 16 | 0.86 | 1.20 | 1.54 | 1.88 | 2.22 | 2.56 | 2.89 | 3.23 | 3.57 | 3.91 | |
| 20 | 1.09 | 1.53 | 1.96 | 2.39 | 2.82 | 3.26 | 3.69 | 4.12 | 4.55 | 4.99 | |
| 24 | 1.33 | 1.86 | 2.38 | 2.91 | 3.43 | 3.96 | 4.49 | 5.01 | 5.54 | 6.06 | |
| 28 | 1.61 | 2.25 | 2.89 | 3.52 | 4.16 | 4.80 | 5.43 | 6.07 | 6.71 | 7.34 | |
| 32 | 1.85 | 2.58 | 3.31 | 4.04 | 4.77 | 5.50 | 6.23 | 6.96 | 7.69 | 8.42 | |
| 36 | 2.08 | 2.91 | 3.73 | 4.55 | 5.38 | 6.20 | 7.02 | 7.85 | 8.67 | 9.49 | |
| 40 | 2.37 | 3.30 | 4.23 | 5.17 | 6.10 | 7.04 | 7.97 | 8.91 | 9.84 | 10.78 | |
| 44 | 2.60 | 3.63 | 4.66 | 5.68 | 6.71 | 7.74 | 8.77 | 9.80 | 10.82 | 11.85 | |
| 48 | 2.84 | 3.96 | 5.08 | 6.20 | 7.32 | 8.44 | 9.56 | 10.69 | 11.81 | 12.93 | |
| 52 | 3.29 | 4.60 | 5.90 | 7.20 | 8.50 | 9.80 | 11.10 | 12.41 | 13.71 | 15.01 | |
| 56 | 3.36 | 4.68 | 6.01 | 7.33 | 8.66 | 9.98 | 11.31 | 12.63 | 13.96 | 15.29 | |
| 60 | 3.59 | 5.01 | 6.43 | 7.85 | 9.27 | 10.68 | 12.10 | 13.52 | 14.94 | 16.36 | |
| 64 | 3.87 | 5.40 | 6.93 | 8.46 | 9.99 | 11.52 | 13.05 | 14.58 | 16.11 | 17.64 | |
| 68 | 4.11 | 5.73 | 7.35 | 8.98 | 10.60 | 12.22 | 13.85 | 15.47 | 17.09 | 18.72 | |
| 72 | 4.34 | 6.06 | 7.78 | 9.49 | 11.21 | 12.93 | 14.64 | 16.36 | 18.08 | 19.79 | |

| Damper Width Inches | Maximum Static Pressure (W.G.) | Maximum Velocity |
|---------------------|--------------------------------|------------------|
| 12 | 5" | 1500 FPM |
| 18 | 4.5" | 1500 FPM |
| 24 | 4" | 1500 FPM |
| 30 | 3.5" | 1500 FPM |
| 36 | 3" | 1500 FPM |
| 42 | 2.5" | 1500 FPM |
| 48 | 2" | 1500 FPM |