



Smoke Damper Airfoil Blade Class I Model 681

Features – U.L. rated for dynamic closure & leakage CLASS I @ 350°F (176°) C.
Meets NFPA 90A & UL555S. Seismic and Fragility tested.

STANDARD CONSTRUCTION

FRAME

4-5/16" (110) deep, 16 gauge (1.6) galvanized steel

BLADES

6 1/2" (165) wide, double wall 20 gauge (1.0) galvanized steel in airfoil shape, equivalent to a 14-gauge (1.9) single skin blade.
(Bottom blade width may vary depending on damper height)

BLADE AXLES & BEARINGS

AXLES – 7/16"(11) Plated hex
BEARINGS – Bronze oil impregnated

LINKAGE

Plated steel concealed inside of jamb

SEALS

Extruded silicone blade edge and stainless steel jamb seals

MULTIPLE SECTIONS

Maximum Single Size is 144"w x 48"h (3658 x 1219)
One actuator on each section (Dynamic Rated)
Available also in 144"w x 96"h (3658 x 2438) (Static Rated)

MAXIMUM U.L. CLASSIFIED LEAKAGE CLASS I SIZES

Single section assemblies - 32" W x 48"H (813 x 1219)

MINIMUM SIZE

12"W x 8"H (305 x 203)

UNDERSIZED

1/4"(102) under ordered size unless specified Exact or Actual

FINISH

Mill

OPERATOR

None

OPTIONAL CONSTRUCTION

SPECIFIED MATERIAL – Available in Stainless

SLEEVE AND DUCTWORK CONNECTION – 10 ga.(3.5) to 20 ga.(1.0) galvanized steel to 30" (762) in length. – Transitions available in: round, oval, rectangular or custom. Factory can install access door, retaining angles, or flange connections.

FINISH – Air-dry primer, polyurethane, epoxy, or enamel, Baked epoxy or enamel.

OPERATOR – Electric or pneumatic, internally or externally mounted, please consult operator listing

* Dampers 11" (279) high and under will be single blade, and extend from the frame proportionately.

SPECIAL PURPOSE CONSTRUCTION

Fully welded corner assembly
Security bars (mounted in sleeve)
Smoke Accessories

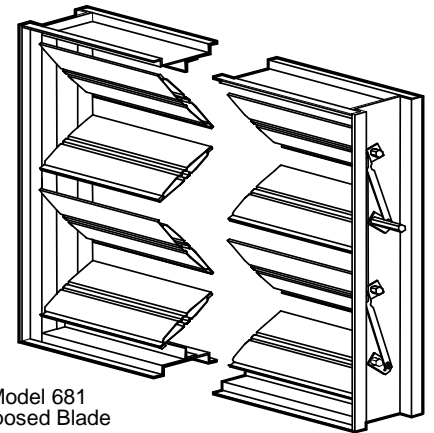
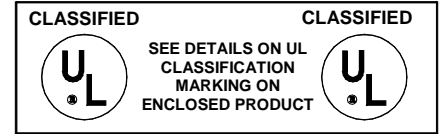

Model 681
Opposed Blade

APPROVED ACTUATORS

	Honeywell	Siemens	Belimo
24 Vac -	ML 8115	GND121.1U	FSNF24 US*
	MS 4309	GGD121.1U	
	MS 8120		
120 Vac -	ML 4115	GND221.1U	FSNF120 US*
	MS 4209	GGD221.1U	
	MS 4120		
230 Vac -		GND321.1U	
		GGD321.1U	
Pneumatic -		331-2961	
		331-3060	

* Only for dampers up to 24" x 24"

ACCESSORIES

Smoke Detector
Indicator Switches
Monitoring Stations

Contractor
Project
Engineer

IMPERIAL DAMPER & LOUVER LLC
4228-38 Park Avenue
Bronx, New York 10457
Phone: 718-731-3800 Fax: 718-731-4920
Email: Sales@ImperialDamper.com
Web: www.ImperialDamper.com