

Fire/Smoke Damper

U.L. Listed

MODEL # 781 –HSP Class I

MODEL # 781-3-HSP Class I

Override & Re-settable

AIRFOIL BLADES

Design Features – U.L. Rated for dynamic closure and classified 1 ½ hour Fire Rated Damper and 3 hour Fire Rated Damper Classified as a Leakage Rated Damper. Leakage Class I @ **250F**
Conforms to NFPA 90A & NFPA 92-A. Classified under U.L. 555 6th edition and UL555S
Qualifies for July 1 2002 specifications. Seismic and Fragility tested.

STANDARD CONSTRUCTION

FRAME - 4 5/16" deep, 16 gauge galvanized steel, Hat shaped design
Equivalent to 13 gauge U channel

BLADES- 6 ½" wide, double wall 20 gauge galvanized steel in
airfoil shape, equivalent to 14 gauge

(Bottom blade may be triple "V" design and vary in height depending on damper height)

BLADE AXLES- 7/16" Plated hex mechanically fastened to blade

BEARING- Bronze oil impregnated self lubricating

LINKAGE- Opposed blade configuration, concealed inside the jamb.

CONTROL ROD - ½" steel rod extending 4 ½" from damper side.

BLADE SEALS- Silicone seals

JAMB SEALS – Flexible Compression Stainless Steel

SLEEVE – 18 Gauge Galvanized steel - 16" long - Raw edges

HEAT RESPONSIVE DEVICE (HRD)- Control Closure Thermostat
Primary -165 degrees F nominal

OVERRIDE / SECONDARY SENSOR (HRD) - Control closure Thermostat
Secondary- @ 250 degrees F nominal

OPERATORS – Electric - 120 volt motor
2 position- non modulating type
Normally Closed Position

END SWITCHES- 1End Switch Showing Open Position
1End Switch Showing Closed Position
Integral in Damper actuator or
Honeywell Dual Auxiliary switch
Wired into common Junction box

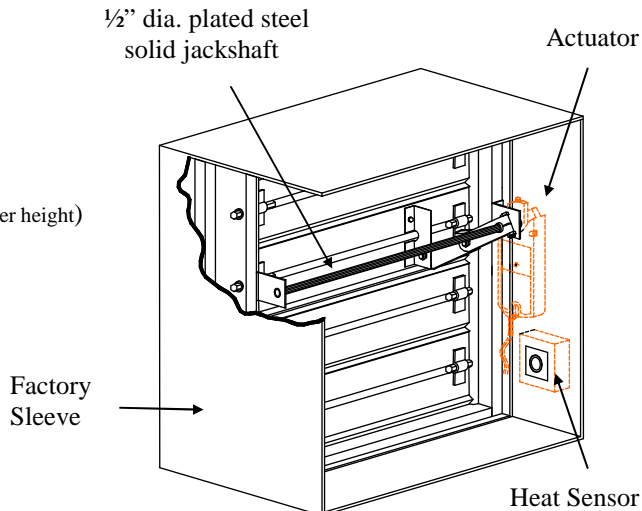
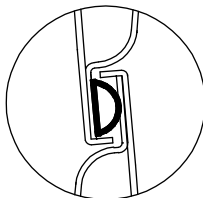

TESTED AND LISTED UNDER U.L.
STANDARD 555S CLASS I 250F
LEAKAGE RATED SMOKE DAMPER

**SENSORS, ACTUATORS, END SWITCHES
LISTED AS A
COMPLETED ASSEMBLY**

NOTE: Additional Sleeve or Side Plate length (over 16") will be added to the non Actuator side

OPERATION SEQUENCE

Damper may be directed to open or close at the discretion of the engineered design concept. Upon activation from the smoke detector the Electric or Pneumatic Motor-actuator cycles the damper to close. Upon excessive duct ambient temperature the HRD interrupts power to the actuator and the actuator's spring return mechanism causes the damper to close. HRD may be bypassed by a remote electrical signal allowing the damper to reopen and remain open until the temperature reaches the setting of the secondary HRD. When the temperature exceeds the secondary HRD, the damper closes and remains closed. When supplied with Pneumatic controls, an EP switch will be required with an appropriate electric power circuit, to allow the electric HRD (thermostat) to control the pneumatic actuator. The HRD's can be reset after the temperature has cooled down below the HRD set point. Before resetting any HRD, a careful inspection of the damper and HRD should be made as exposure to actual fire conditions may render these devices unusable. See Installation Instructions, prior to installation

Contractor: _____

Project: _____

Engineer: _____

IMPERIAL DAMPER & LOUVER LLC
4228-38 Park Avenue
Bronx, New York 10457
Phone: 718-731-3800 Fax: 718-731-4920
Email Inquiry@Imperialdamper.com

All stated specifications are subject to change without notice or obligation.